

COMREON[®] Lecturer Tracking Camera

User Manual V1.1

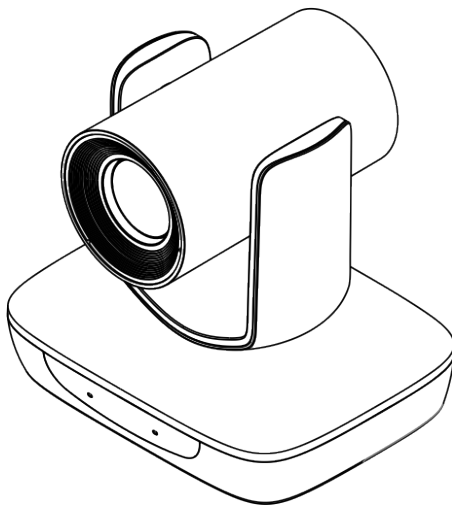

SAFETY NOTES

The following important notes must be followed carefully to run the camera and respective accessories in total safety. The camera and relative accessories are called video system in this section.

- Before installing the camera, please read this manual carefully. Please follow installation instructions indicated in this manual during installation. Please keep this manual for future use.
- The installation should be performed by qualified service personnel or system installers in accordance with all local rules.
- Before powering on the camera, please check the power voltage carefully. Make sure that you are using the correct power source.
- Please put the power cable, video cable and control cable in safe place.
- Do not operate the camera beyond the specified temperature and humidity. Working temperature range of the camera is between 0°C ~ +40°C. The ambient humidity range is 10%RH ~ 90%RH.
- During transporting, avoid violent shake or force to the camera.
- To prevent electric shock, do not remove screws or housing of the camera. There are no self-serviceable parts inside. Refer to qualified service personnel for servicing.
- Never aim the lens of the camera at the sun or other extremely bright objects. Otherwise, it may cause damage.
- When cleaning the camera, please use soft cloth. If the camera is very dirty, wipe it off gently with a soft cloth moistened with a weak solution of water and a neutral kitchen detergent. Wring all liquid from the cloth before wiping the camera, then wipe off all remaining dirt with a soft, dry cloth. Use lens cleaning paper to clean the lens.

- Do not move the camera head manually. In doing so would result in malfunction of the camera. Do not hold the camera head when carrying the video camera.
- This camera is for indoor use only. It is not designed for outdoor use.
- Make sure the camera is not directly exposed to rain and water.
- Make sure the camera is far away from area where radiation, X-rays, strong electric waves, or magnetism is generated.

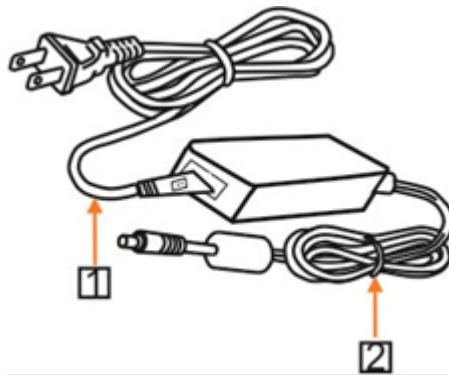

⚠ Warnings

1. If you need to extend the power cable, please extend the power cable from the part on below picture (220V/110V), do not extend from part 2 on below picture (DC12V), otherwise it will cause unexpected damage to the device.
2. To prevent infringement of the rights of others, please confirm that it is installed and used within the scope permitted by local law!

CONTENTS

CONTENTS	1
ABOUT THE PRODUCT	1
QUICK GUIDE	1
ABOUT THE PRODUCT	2
FEATURES	2
LIST OF PARTS & ACCESSORIES	2
MAIN PARTS & INTERFACES	3
DIP SWITCHES SETTINGS	4
REMOTE CONTROLLER	5
INSTALLATION	7
DESKTOP MOUNT INSTALLATION	7
WALL MOUNT INSTALLATION (OPTIONAL)	7
CONNECTIONS	8
MENU SETTINGS	9
MENU CONFIGURATION	9
MENU EXPLANATION	13
VIDEO	14
EXPOSURE	14
COLOR	15
PAN/TILT/ZOOM	16
SYSTEM	16
STATUS	17
RESTORE DEFAULTS	17
LIST OF SPECIAL PRESET COMMANDS	17
NETWORK CONNECTION	18

LAN CONNECTION-----	18
WAN CONNECTION-----	18
CLIENT SOFTWARE INSTRUCTION-----	21
SEARCH AND LIST THE CAMERA-----	21
SETTING-----	26
SOFTWARE CONNECTION-----	26
ANNEX 1 TECHNICAL SPECIFICATIONS-----	28
ANNEX 2 SIZE AND DIMENSION-----	30
TROUBLESHOOTING-----	31

ABOUT THE PRODUCT

Quick Guide

The camera can be accessed and controlled via the following ways:

- Client software CameraCMS: camera search and control, network setting;
- VLC: watch the camera two streams;
- IE: camera image preview, camera control, network setting;
- Onvif: version 2.1 supported
Name: admin
Initial password: 123456
- Network pass-through: recommended connection mode with recording or streaming device.

CameraCMS

Refer to detailed instructions in page 21 of this user manual.

Rtsp

- 1 Make sure PC and the camera are in the same LAN.
- 2 Two channel streams, url: rtsp://IP/chx, x=1, 2.
- 3 IP address is acquirable through CameraCMS, default rtsp port is 554.

IE

- 1 Make sure PC and the camera are in the same LAN;
- 2 Input IP address+ port number 88 (port numbers fixed to 88) in the IE address bar: http://IP:88, such as http://192.168.18.229:88
- 3 Install plug-in;
- 4 Name: admin Initial password: Null;
- 5 Support Windows 7 or above operation system, whereas Windows XP is not supported.

Network Pass-Through

On the tracking parameters setting page, the IP address, port and connection protocol (TCP/UDP) of the recording or streaming device can be configured. After connected, the camera can be controlled by the standard VISCA protocol. Recording or streaming device can achieve audio & video of the camera through rtsp or rtmp.

ABOUT THE PRODUCT

Features

- Built-in industry-leading baby detection and lock tracking image algorithm;
- 1/2.8 inch CMOS sensor, 2.14 megapixel;
- 20x optical zoom, Max FOV: 59.5°;
- Support HDMI, 3G-SDI, Network, USB, up to 1080P60 video output;
- 1 channel audio LINE IN, AAC Compression;
- Support two modes of power supply, POE (optional) power supply or adapter power supply;
- Support VISCA interface and protocol, support flow control;
- Dual stream.

List Of Parts & Accessories

When you open the box, check all accessories according to the packing list.

Camera (1)

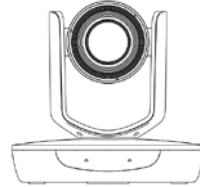

Power Adapter (1)

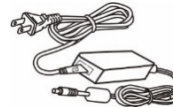

Remote Controller (1)



RS-232 Control Cable (1)



Main Parts & Interfaces

Camera

Front View

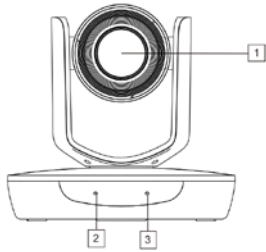

- 1 Camera Module
- 2 Communication Indicator
- 3 Power Indicator

Rear View

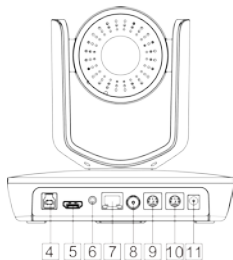

- 4 USB
- 5 HDMI Video Output
- 6 LINE IN
- 7 Network
- 8 SDI
- 9 RS-232IN/IR
- 10 RS-232OUT/RS-485
- 11 DC12V

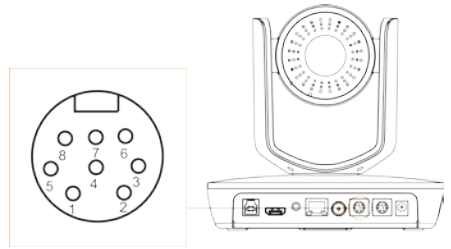

RS-232IN/IR Pin Definition	
Number	Definition
1	/
2	/
3	232-TX
4	GND
5	232-RX
6	GND
7	IR
8	/

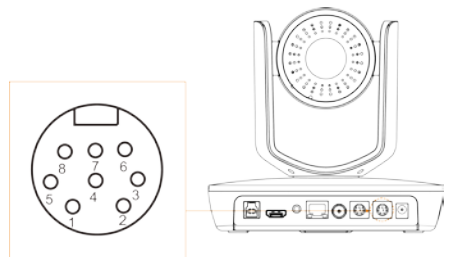

RS-232OUT/RS-485 Pin Definition	
Number	Definition
1	/
2	/
3	232-TX
4	GND
5	232-RX
6	GND
7	485+
8	485-

Bottom View

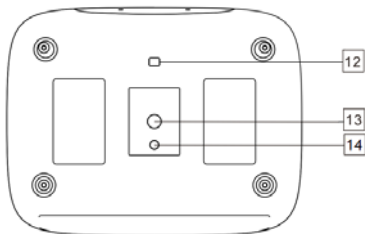

12 DIP Switch

Set camera video format and menu.

13 Mounting Hole

1/4"inch screw thread for fixing camera.

14 Locating Hole

To define installation direction of camera.

DIP Switches Settings

Before installing and operating the camera, set video output format and menu through DIP switches. The camera has two 4-digit DIP switches. SW as below:



SW Settings

No 1-4 is used to set video output format and menu. Refer to below chart for details:

SWITCH NO.	SW			
	1	2	3	4
1080P25	OFF	ON	ON	ON
1080P30	ON	OFF	ON	ON
720P50	OFF	OFF	ON	ON
720P60	ON	ON	OFF	ON
1080i50	OFF	ON	OFF	ON
1080i60	ON	OFF	OFF	ON
1080P50	OFF	OFF	OFF	ON
1080P60	ON	ON	ON	OFF
MENU	ON	ON	ON	ON

Please change video formats through special presets.

Note

PTZ reboot is necessary for the new setting to take effect.

Remote Controller

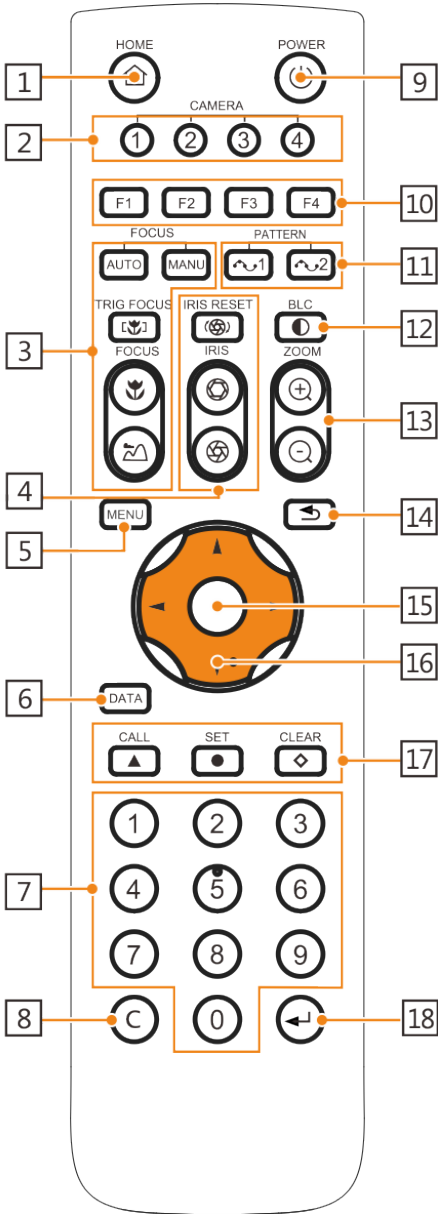

1 HOME

Press **HOME** button, camera moves to initial position.

2 Camera Selection Button

Used to switch among 4 cameras, press 1-4 number buttons to control cameras with 1-4 addresses respectively. For example, press button 1 to control the camera with address 1.

3 Focus



Press "AUTO" button to switch to Auto Focus, press "MANU" button to switch to Manual Focus mode.

"" button to Focus Near

"" button to Focus Far

"" button to Auto Focus once every time it is pressed, then switch back to Manual Focus mode.

4 Iris

Press "" button to reset iris (image brightness) value to default. "" button to Iris Open (brighter image)

"" button to Iris Close (darker image).

5 Menu

Press **MENU** button to enter / exit menu.

6 Data

Reserved.

7 Number Keys

Used to input numbers, for example, preset number.

8 Cancel

To cancel numbers input

9 Power

After the camera has been connected to power source, in none-menu status, press this button to turn on / off the camera.

10 Reserved Buttons (F1, F2, F3, F4)

Reserved.

11 Pattern

Reserved.

12 BLC

Used to open / close back light compensation.

13 Zoom

Used to adjust zooming times.

“”button to zoom in

“”button to zoom out.

14 Back

Press“”button to go back to previous menu.





15 OK

In None-menu status: press this button to switch among pan / tilt control speeds.

In Menu status: get into relative menu option after it has been selected.

16 Direction / Menu Operation

In None-menu status, press these four buttons to pan left/right and tilt up/down.

In Menu status: or  button to select among menu options,  or  to change option / value.

17 Preset Setting

“” button to call a preset.

Input number key(s), and then press this button to call a preset.

“”button to set a preset.

Move the camera to a specific position, adjust focus value and etc, and then press this button to set a preset.

“”button to clear a preset.

Input number key(s), and then press this button to clear a preset.

18 Enter

After inputting numbers, press this button to confirm.

INSTALLATION

The camera has 2 installation types: desktop and wall mount installations (optional).

Note

Make sure the installed place is strong and safe enough to hold the camera and relative parts, it is suggested that the installed place can withstand 4 times the weight of the camera and its relative parts.

Desktop Mount Installation

1. Put the camera on a flat surface. In case the camera has to be placed on an inclined surface, make sure the cline angle is less than 15 degrees to ensure proper pan /tilt operation.

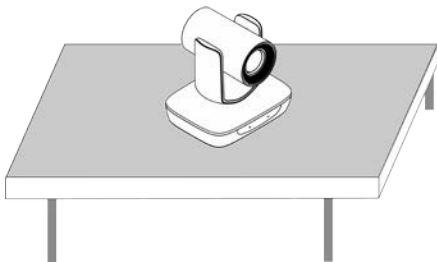

Note

- Take effective measures to avoid camera from dropping.
- Do not grab the camera head when carrying.
- Do not rotate the camera head with hand. It may cause malfunction to the camera.

Wall Mount Installation (Optional)

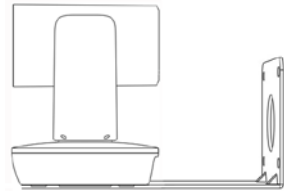

1. According to diameter and position of the 4 installation holes (As shown below) on the bracket, drill 4 holes on the wall and fix the bracket onto the wall by using 4 screws which should be prepared by you.

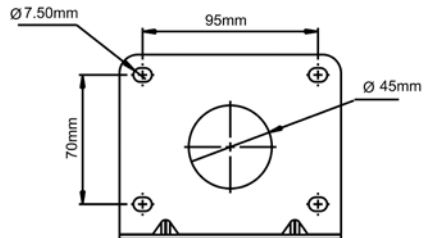

2. Before fixing the camera, set the DIP switches of the camera correctly.

3. Use inch screws to fix the camera on the bracket, fix the limit screw according to actual requirement, and make sure the camera is tightly fixed onto the bracket before your hands leave the camera.

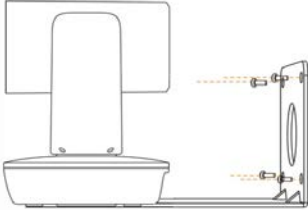

CONNECTIONS

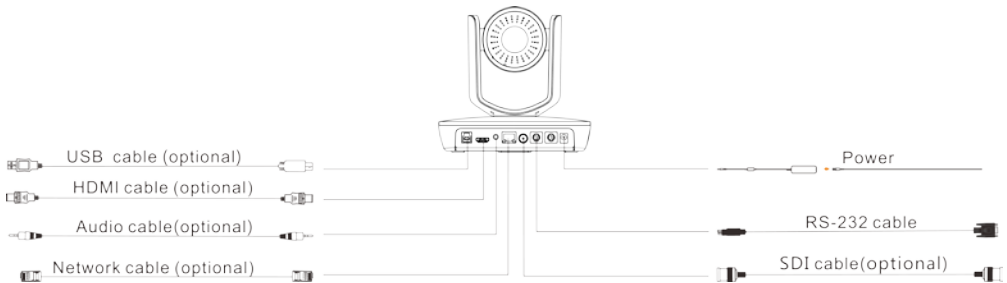

Note

If preset 0 has been saved, after powered on, camera moves to preset 0 automatically; if preset 0 has not been saved, after powered on, camera moves to Home position, where both pan and tilt angle is zero and zooming time is 1x.

MENU SETTINGS

Menu Configuration

<VIDEO>	—	IMAGE MODE	——	STAND, MIRROR
Refer to Page 14	—	SHARPNESS	——	0, 1, 2, 3, 4, 5, 6, 7, 8, 9, 10, 11, 12, 13, 14, 15
	—	BRIGHTNESS	——	0, 1, 2, 3, 4, 5, 6, 7, 8, 9, 10, 11, 12, 13, 14
	—	CONTRAST	——	0, 1, 2, 3, 4, 5, 6, 7, 8, 9, 10, 11, 12, 13, 14
	—	GAMMA MODE	——	0, 1, 2, 3, 4
	—	2DNR LEVEL	——	1, 2, 3, 4, 5, OFF
	—	3DNR LEVEL	——	1, 2, 3, 4, 5, OFF
	—	WIDE DYNAMIC	——	1, 2, 3, 4, 5, OFF

<EXPOSURE>
Refer to Page
14

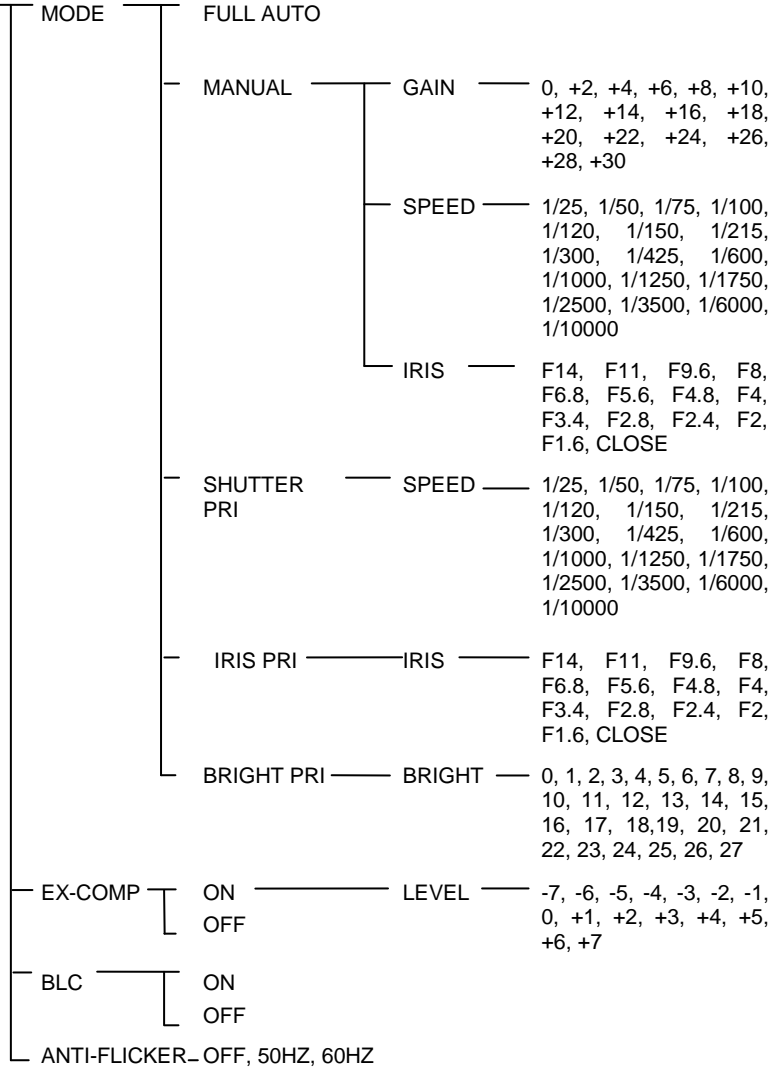

<COLOR> Refer to Page 15	WB MODE	—	AUTO, ATW, ONE PUSH, INDOOR, OUTDOOR, MANUAL, SODIUM LAMP, FLUO LAMP
	SATURATION	—	0, 1, 2, 3, 4, 5, 6, 7, 8, 9, 10, 11, 12, 13, 14
	HUE	—	0, 1, 2, 3, 4, 5, 6, 7, 8, 9, 10, 11, 12, 13, 14

<PAN TILT ZOOM> Refer to Page 16	PAN/TILT SPEED	—————	1, 2, 3, 4, 5, 6, 7, 8
	D-ZOOM LIMIT	—————	X1, X2, X3, X4, X5, X6, X7, X8, X9, X10, X11, X12
	PTZ TRIG AF	—————	ON, OFF
	RATIO SPEED	—————	ON, OFF
	POWER UP ACTION	—————	PRESET 1, PRESET 2, PRESET 3, PRESET 4, PRESET 5, PRESET 6, PRESET 7, PRESET 8, PRESET 9, HOME

< SYSTEM > Refer to Page 16	ADDRESS	—————	1, 2, 3, 4, 5, 6, 7
	PROTOCOL	—————	VISCA, PELCO-P, PELCO-D
	BAUDRATE	—————	2400, 4800, 9600, 38400
	IR ADDRESS	—————	1, 2, 3, 4
	VIDEO FORMAT	—————	1080P60, 1080P50, 1080I60, 1080I50, 1080P30, 1080P25, 720P60, 720P50
	MOUNT MODE	—————	STAND, CEILING
	RS485 PORT	—————	HALF-DUPLEX-1, HALF-DUPLEX-2
	LANGUAGE	—————	ENGLISH

<STATUS>	ADDRESS	1
Refer to Page 17	PROTOCOL	VISCA
	BAUD RATE	9600
	IR ADDRESS	1
	VIDEO FORMAT	1080P25
	MOUNT MODE	STAND
	FIRMWARE VER	1.0.06

<RESTORE DEFAULTS> Refer to Page 17

Menu Explanation

Main Menu

Main Menu Call Preset #95 to enter menu.

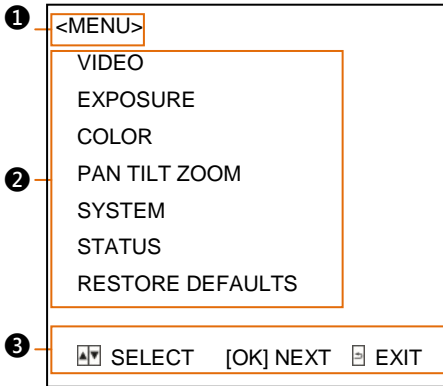

1 Menu Title

It displays currently selected menu option

2 Menu Options

It displays options under current menu title.

Click UP or DOWN button to select among menu options, once color of options turned to different color, it indicates the menu has been elected, click IRIS+ button to get into this menu.

Submenus

From main menu, navigate to select

<EXPOSURE> menu, click IRIS  to enter.

<EXPOSURE>Set menu.

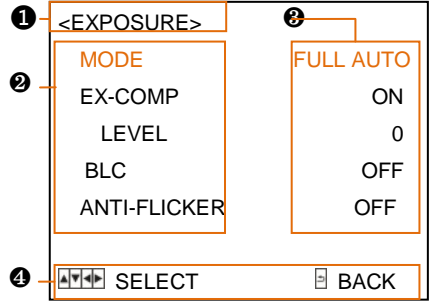



1 2 Please refer to the same controls to the Main Menu

3 Menu options

Click ◀ or ▶ to change the values.

Video

VIDEO menu is used to change video value.

<VIDEO>	
IMAGE MODE	STAND
SHARPNESS	8
BRIGHTNESS	7
CONTRAST	2
GAMMA MODE	0
2DNR LEVEL	OFF
3DNR LEVEL	OFF
WIDE DYNAMIC	OFF
 SELECT	 BACK

Available Options:

IMAGE MODE: STAND, MIRROR.

SHARPNESS: 0, 1, 2, 3, 4, 5, 6, 7, 8, 9, 10, 11, 12, 13, 14, 15.

BRIGHTNESS: 1, 2, 3, 4, 5, 6, 7, 8, 9, 10, 11, 12, 13, 14.

CONTRAST: 1, 2, 3, 4, 5, 6, 7, 8, 9, 10, 11, 12, 13, 14.

GAMMA MODE: 0, 1, 2, 3, 4.



2DNR LEVEL: 1, 2, 3, 4, 5, OFF.

3DNR LEVEL: 1, 2, 3, 4, 5, OFF.

WIDE DYNAMIC: 1, 2, 3, 4, 5, OFF.

Exposure

EXPOSURE menu is used to adjust exposure value.

<EXPOSURE>	
MODE	FULL AUTO
EXP-COMP	ON
LEVEL	0
BLC	ON
ANTI-FLICKER	OFF
 SELECT	 BACK

MODE:

FULL AUTO: Gain, Shutter Speed and Iris value are adjusted automatically accordingly to working environment.

MANUAL: manually adjust Gain, Shutter Speed and Iris.

GAIN: 0, +2, +4, +6, +8, +10, +12, +14, +16, +18, +20, +22, +24, +26, +28, +29, +30.

SPEED: 1/25, 1/50, 1/75, 1/100, 1/120, 1/150, 1/215, 1/300, 1/425, 1/600, 1/1000, 1/1250, 1/1750, 1/2500, 1/3500, 1/6000, 1/10000.

IRIS: F14, F11, F9.6, F8, F6.8, F5.6, F4.8, F4, F3.4, F2.8, F2.4, F2, F1.6, CLOSE.

SHUTTER PRI: Gain and Iris value are adjusted automatically according to working environment; shutter speed value is adjustable manually.

SPEED: 1/25, 1/50, 1/75, 1/100, 1/120, 1/150, 1/215, 1/300, 1/425, 1/600, 1/1000, 1/1250, 1/1750, 1/2500, 1/3500 , 1/6000, 1/10000.

IRIS PRI: Gain and shutter speed value are adjusted automatically according to working environment; Iris value is adjustable manually.

IRIS: F14, F11, F9.6, F8, F6.8, F5.6, F4.8, F4, F3.4, F2.8, F2.4, F2, F1.6, CLOSE.

BRIGHT PRI: Manually adjust the video brightness.

BRIGHT: 0, 1, 2, 3, 4, 5, 6, 7, 8, 9, 10, 11, 12, 13, 14, 15, 16, 17, 18, 19, 20, 21, 22, 23, 24, 25, 26, 27.

EXP-COMP: Once EXP-COMP is set as On, below level options become available -7, -6, -5, -4, -3, -2, -1, 0, +1, +2, +3, +4, +5, +6, +7 +7 is the maximum compensation value for bright, -7 is the maximum compensation value for dark.



BLC: ON, OFF.

Backlight compensation (BLC) is video gain done automatically to correct the exposure of subjects that are in front of a bright light source.

ANTI-FLICKER (OFF, 50Hz, 60Hz): To avoid video flicker at power systems of different frequency.

Color

COLOR menu is used to adjust color related values. Available options:

< COLOR >	
WB MODE	MANUAL
R.GAIN	7
B.GAIN	7
SATURATION	7
HUE	7
 SELECT	 BACK

WB MODE: AUTO, ATW (auto tracking), ONE PUSH, INDOOR, OUTDOOR, MANUAL, SODIUM LAMP, FLUO LAMP.

“ONE PUSH”: In “ONE PUSH TRIGGER” mode, aim the camera at a pure white object (say a white paper), then press  button.

“AUTO” mode: R.GAIN, G.GAIN and B.Gain can be chosen from -7~+7.

“MANUAL” mode: R.GAIN and B. GAIN value can be chosen from 0~255.

SATURATION: 0, 1, 2, 3, 4, 5, 6, 7, 8, 9, 10, 11, 12, 13, 14.

HUE: 0, 1, 2, 3, 4, 5, 6, 7, 8, 9, 10, 11, 12, 13, 14.

Pan/Tilt/Zoom

PAN/TILT/ZOOM is used to change pan/tilt/zoom value, available options:

<PAN TILT ZOOM>	
PAN/TILT SPEED	8
D-ZOOM LIMIT	X1
PTZ TRIG AF	ON
RATIO SPEED	ON
POWER UP ACTION	HOME
SELECT	BACK

PAN/TILT SPEED: 1, 2, 3, 4, 5, 6, 7, 8 the bigger the number is, the faster the speed is.

D-ZOOM LIMIT: X1, X2, X3, X4, X5, X6, X7, X8, X9, X10, X11, X12.

PTZ TRIG AF: Turn ON / OFF the auto focus when the camera pans / tilts / zooms.

RATIO SPEED (ON, OFF): Set the relation of PT speed as per zoom time. When it's on, PTZ speed will be faster when zoom time is bigger.

POWER UP ACTION: PRESET 1, PRESET 2, PRESET 3, PRESET 4, PRESET 5, PRESET 6, PRESET 7, PRESET 8, PRESET 9, HOME.

System

<SYSTEM>	
ADDRESS	1
PROTOCOL	VISCA
BAUD RATE	9600
IR ADDRESS	1
VIDEO FORMAT	1080P25
MOUNT MODE	STAND
RS485 PORT	HALF-DUPLEX-1
LANGUAGE	ENGLISH
SELECT	BACK

ADDRESS: 1, 2, 3, 4, 5, 6, 7.

PROTOCOL: VISCA, PELCO-D, PELCO-P;

BAUD RATE: 2400, 4800, 9600, 38400;

IR ADDRESS: 1, 2, 3, 4, set camera address to be controlled by remote controller.

VIDEO FORMAT: 1080P60, 1080P50, 1080P30, 1080P25, 1080I60, 1080I50, 720P60, 720P50;

MOUNT MODE: STAND, CEILING;

RS485 PORT:

HALF-DUPLEX-1: the camera will not return ACK/FINISH/FAULT msg.

HALF-DUPLEX-2: the camera will return ACK/FINISH/FAULT msg.

LANGUAGE: ENGLISH.

STATUS



< STATUS >	
ADDRESS	1
PROTOCOL	VISCA
BAUD RATE	9600
IR ADDRESS	1
VIDEO FORMAT	1080P25
MOUNT MODE	STAND
FIRMWARE VER	V1.0.06
 BACK	

Display information (address, protocol, baud rate, IR address, video format, mount mode and firmware version) of the current camera.

Restore Defaults

< RESTORE DEFAULTS >	
PRESS OK	CONFIRM
PRESS BACK	CANCEL

RESTORE DEFAULTS option is used to reset all menus to default value.

Press  to confirm or press  to cancel and return to previous menu.

List Of Special Preset Commands

Preset No.	Function
0	Full-View
1	Tracking
8	Track the left-bound preset
9	Track the right -bound preset
80	Turn on tracing
81	Turn off tracing
93	Cruise, camera switches among saved 0~29 presets repeatedly and sequentially in fixed interval.
95	Get into menu
96	Delete all presets
99	Reboot the PTZ

Network Connection

Connect the camera to network with an Ethernet cable, power on the camera.

LAN Connection

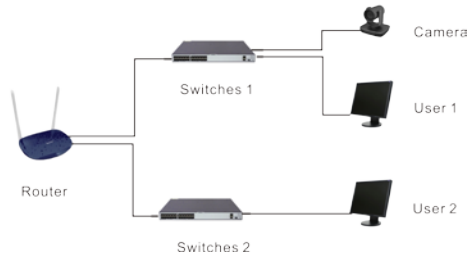

Please refer to the above diagram, user1 and user 2 are in the same router, they are considered as in the same LAN, connect the camera to the same LAN as where the PC is, and refer to below instructions as how to use the application software, then the camera can be found and connected from the online device list.

WAN Connection

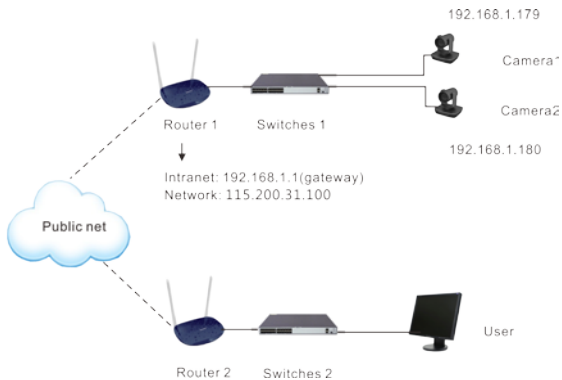

Please refer to the above diagram, user and the camera are in different routers, they are considered as in a WAN; in this condition, application software CameraCMS can not search and find the camera automatically. User can still connect after below conditions are satisfied.

(1) Set camera's IP address as static IP address.

Set camera's IP address in LAN: connect user PC to the LAN (Router 1) where the camera is connected according to LAN connection instructions, use application software CameraCMS to search and find the camera, then add it to manage; then set camera's IP address in the same network segment as the router 1. Camera's gateway is usually set at Router 1's LAN IP address, for example, 192.168.1.1, then camera's IP address can be set as for example 192.168.1.179 or 192.168.1.180 as long as they are in the same network segment.

(2) Router of the LAN where camera is connected supports Port Mapping.

Route Mapping: User PC logs into router configuration menu, gets into "Port Mapping" (router management authorization may be required); refer to below picture, DO NOT tick "Do not apply this rule", from first frame under "External port", input any number from 1-65535, but preferred to be set at more than 10000 like 10200 so there will be less port conflict possibility. From "Internal IP", input the camera's IP address 192.168.1.179, from first frame of "Internal Port", input 3478, (all cameras use this same port number). "Protocol" and "Mapping Line" can be default, from "Note", input "Camera 1's mapping port" or something to understand.

Port mapping

List of rules	
Not applied	<input type="checkbox"/> Do not apply this rule If you disable this rule, the following configuration will only be saved but will not applied.
External port	<input type="text"/> <input type="text"/> You can input an external port or an external port segment to be mapped to an open port or port segment of an internal host. If you leave it blank, the external port or port segment is identical to the internal port or port segment. The range is between 1 and 65535.
Internal IP	<input type="text"/> The IP address of the internal host that provides external service. For example:192.168.0.50
Internal port	<input type="text"/> <input type="text"/> The open port or port segment of the internal host that provides external services. The range is between 1 and 65535.
Protocol	<input type="text" value="TCP"/> <input type="button" value="v"/> The protocol used for port mapping can be TCP, UDP or both.
Mapping line	<input type="text" value="Any"/> <input type="button" value="v"/> The line used for port mapping can be single WAN or multi WAN.
Note	<input type="text"/> You can write a short note to describe this mapping rule. For example:The WEB server for Marketing Department.

Help

Port mapping function can map the service port of the intranet server host to extranet, so external network users can access the services offered by the intranet server through the external IP address and port of the router.

Notice:

- Port mapping works only if "Block extranet requests" on the Attack defense page is disabled.

(3) Router of the LAN where camera is connected has fixed public IP address.

Access from external network: Router 1's public IP address is 115.200.31.100, for example, go through the above steps one and two, WAN users under router 2 can access camera 1 through IP address 115.200.31.100 + port 10200. Then, in WAN, the mapping of camera 1 and (IP 115.200.31.100 + port 10200) is established. Camera 2 can use another external port such as 10320, so mapping of camera 2 with (IP 115.200.31.100 + port 10320) is established. In the "Managed Device" of the client software CameraCMS, click "+ Add", enter the IP address 115.200.31.100 and port 10200 and other information, then the camera 1 can be accessed and controlled.

Client Software Instruction

Search And List The Camera

Install and open the client software in PC, enter the main interface:

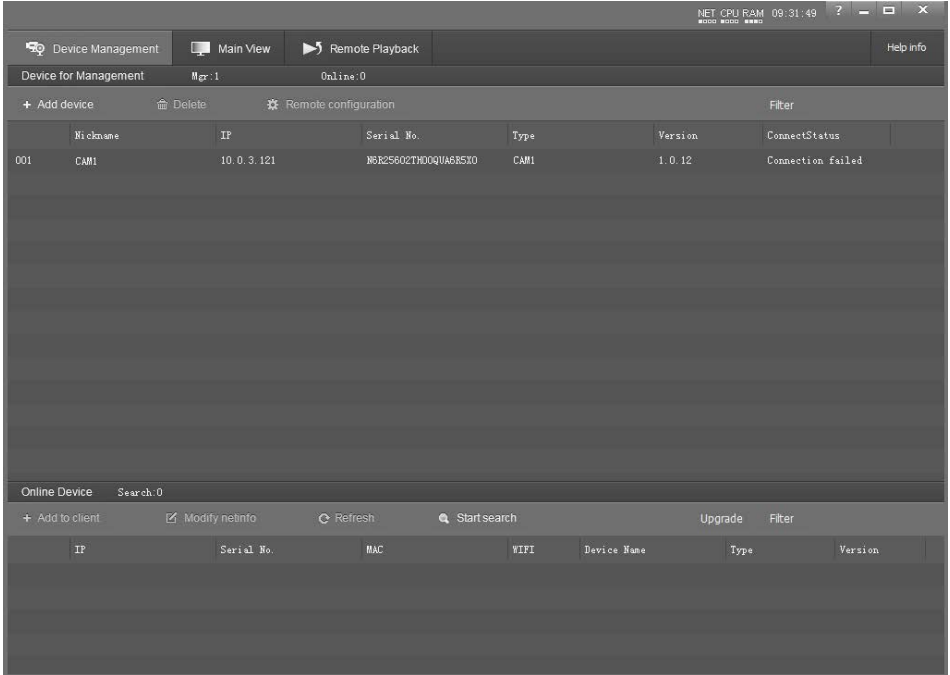

If the camera and PC are in the same LAN, click **Start Search**, then searching starts and all online devices will be listed, as the picture shown below:

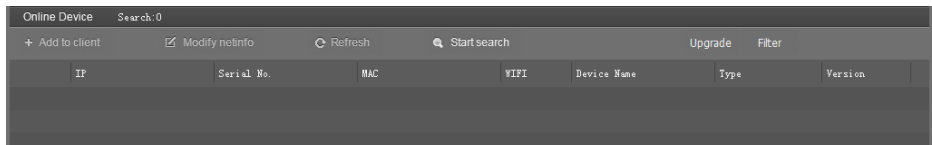

To modify the device IP address, input the IP address, mask, gateway in the **Modify Network** column.

X

Modify Network Parameter

Ethernet

Device information:

CameraName:

Mac:

SN:

Network information:

ConnType:

IP:

Mask:

GateWay:

DNS1:

DNS2:

Modify

To control and preview a camera, first choose the device, modify its IP address as the IP address of the same LAN, then click **Add to Client** as the picture shown below.

+ Add to client
☑ Modify netinfo
↻ Refresh
🔍 Stop search
Upgrade
Filter

	IP	Serial No.	MAC	WiFi	Device Name	Type	Version
010	10.0.3.179	X3I2E10CT00NQW2M035	00:04:05:0F:6A:C0	No	CAM1	CAM1	1.0.12
011	10.0.3.236	R1V5K402U702QW5A4E4	00:04:05:0F:70:97	No	CAM2	CAM2	1.0.35

Please check that all IP addresses are in the same LAN.

Preview

Click **Main View** to get into camera control and preview part as below.

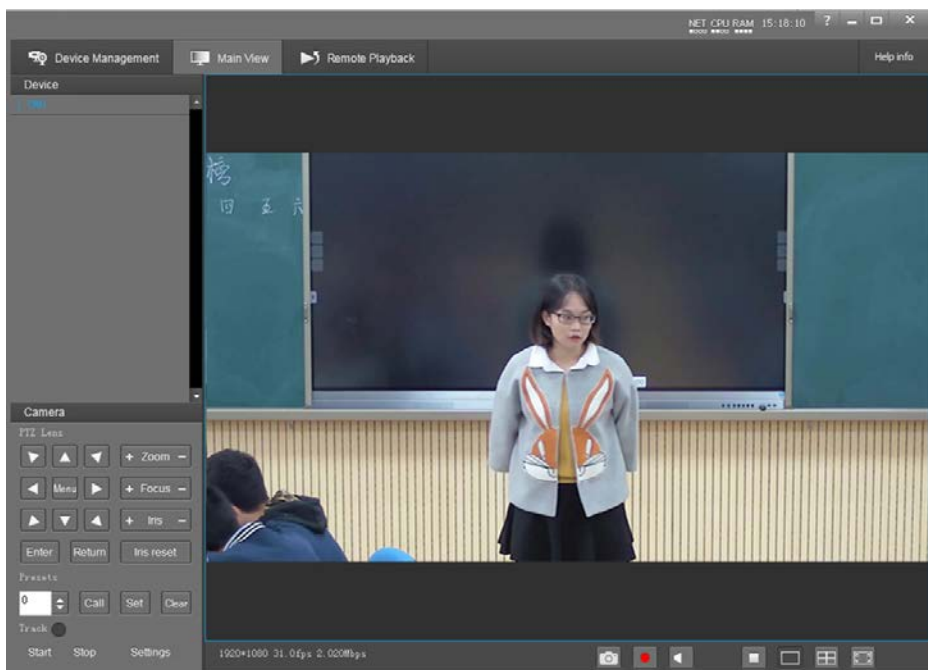
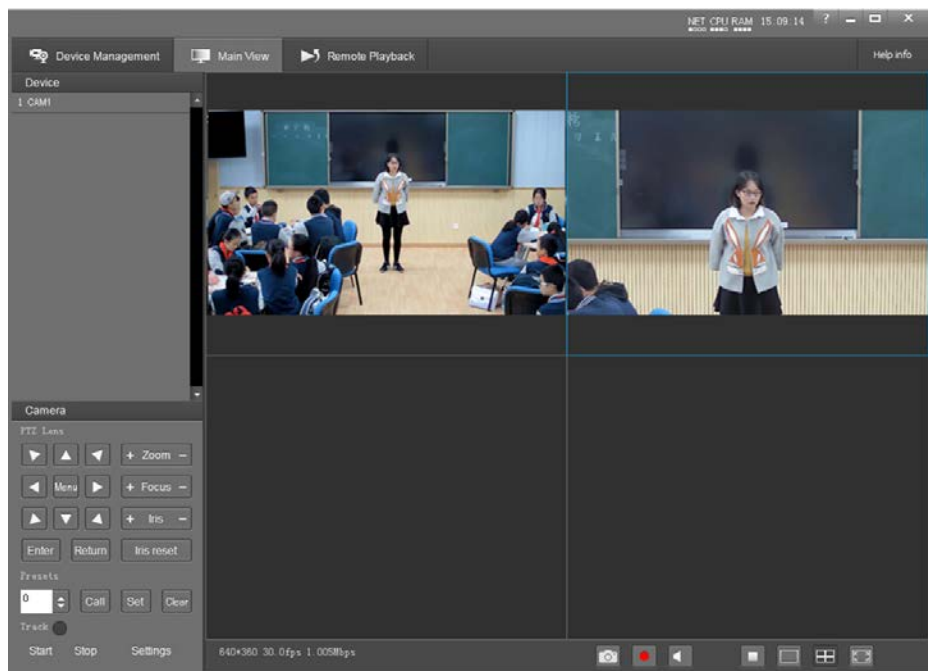

This interface includes three main parts: Device List, Device Control, Video Preview.

- Device: it displays all online cameras added to “Device Management”.



- Device Control: get control of the selected camera (camera name in blue).

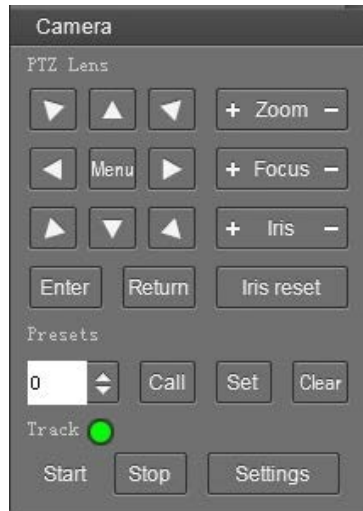

- Video Preview: double click the camera in the list, main camera stream will be displayed in the preview window; or right click the selected camera from the left column to get its main or substream video. Video preview mode can be single video or four video's, when in four video's mode, select one of the four video's then choose the bottom right icon to enlarge this selected video to a big single window.

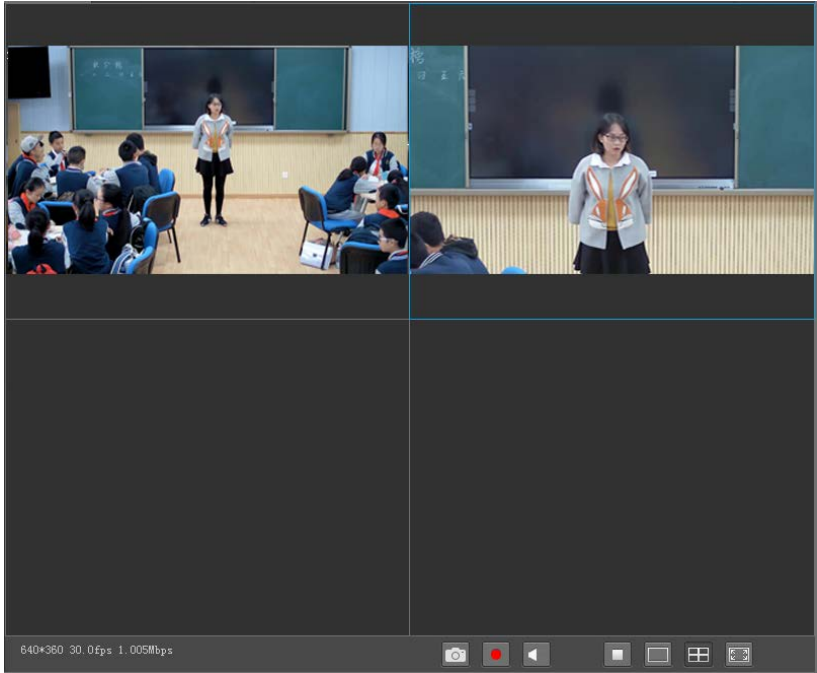

Setting

Software Connection

If you want to track settings, you can Install and turn on “CameraCMS”, click on **Start** **Search** / **Add to client** / **Main View** / **Track** / **Settings**.

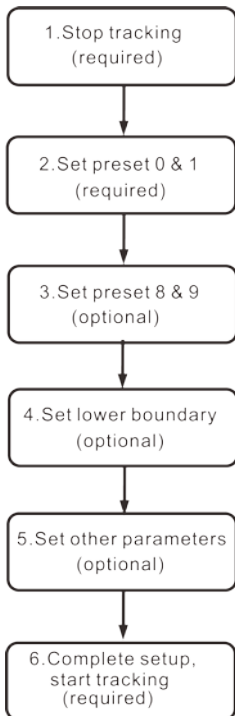

1. Stop tracking



Stop: turn off tracking, using controller or software to call preset 81 can also turn off tracking.

2. Set preset 0 & 1

Preset 1: preset 1 is the position where tracking starts, preferred to be set at Podium; to configure it, move the camera's Pan/Tilt/Zoom to put the lecturer in the appropriate size and position in the image, as shown in the figure below, then set it as preset 1.



Preset 0: it is a position that can be configured to have the camera move to once tracked object gets lost, recommended to set at a full view image of the lecturing area. See basic parameter settings for details.

3. Set preset 8 & 9

Tracking left and right limit: if set (not specified): you could set 8 as the limit on the left, 9 as the limit on the right; Or set 8 to the right limit and 9 to the left limit), and the camera horizontal tracking will be between these two preset positions. If the target exceeds the limit, it returns to the 0 position.

If not set (default is not set) the entire process is tracked.

4. Set lower boundary, the default line is in the center of the image.



Start tracking the target altitude line:

When the camera is target-free (at bit 0), the detected target head must be higher than the line before camera tracking can be triggered.

In order to avoid untracked targets (such as sitting students) triggering tracking by mistake

5. Set other parameters, default values are recommended.

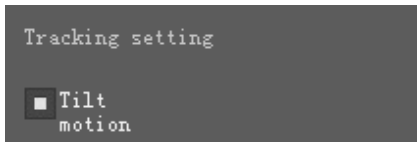

Tilt Motion: when it's enabled, the camera will automatically adjust tilt angle during tracking.

When it's disabled, the camera will track as per the tilt angle of preset 1.

If the lecturer does not walk into the student area, it's suggested to disable auto zoom and tilt motion.

Tracking Parameters



Track Sens: set sensitivity of tracking based on speed of movement. High sensitivity will track at small movement.

Track Speed: set pan speed for tracking;

Lost Timeout: set the interval before Object lost action will be performed, (go to preset 1 or 0). Default is 5 seconds.



Power On State: the action to be performed when the camera is powered on.

6. complete setup, start tracking

Start: turn on tracking, using controller or software to call preset 80 can also turn on tracking.

Settings: click this button to get into detailed tracking parameters for configuration.

ANNEX 1 TECHNICAL SPECIFICATIONS

Items	Value
Image Sensor	1/2.8" CMOS, 2.14 megapixel
Focal Lens	f=4.7~94.0mm
Optical Zoom	20x
Digital Zoom	12x
Iris	F1.6~F3.5
Horizontal Viewing Angle	59.5° - 2.9°
Focus System	Auto, Manual, PTZ Trigger, One Push Trigger
Shutter Speed	1/1s to 1/10,000s
Gain	Auto, Manual
White Balance	Auto, Indoor, Outdoor, One Push, Manual, Auto Tracking
Exposure Control	Auto, Manual, Shutter Priority, Iris Priority
S/N	≥55dB
Menu	English
PTZ	
Pan Angle	-170°~+170°
Tilt Angle	-30°~+90°
Pan Speed	0.2°/S~100°/S
Tilt Speed	0.2°/S~60°/S
Preset Number	64
Video Output	
Video Format	1080P60, 1080P50, 1080P30, 1080P25, 1080I60, 1080I50, 720P60, 720P50
NETWORK	
Resolution	Max 1920*1080P60
Image Compression	H.265, H.264

Audio Compression	AAC
Protocols	ONVIF, RTSP, RTMP, HTTP, TCP, UDP
Dual Stream	Support
USB	
USB Interface	USB2.0 Type-B
UVC, UAC	Support
Video Interface	H.264 / MJPEG
Image Size	1920x1080, 1280x720, 640x360
Interface	
Video Interface	HDMI 1.4 / 3G-SDI
Network Interface	RJ45 (100M) interface, Reserved power over Ethernet
Control Interface	RS-485 / RS-232
General	
Protocols	VISCA, PELCO-D
Address	0~63
Power	DC12V
Power Consumption	<15W
Operating Temperature	0°C~+40°C
Storage Temperature	-20°C~+60°C
Operating Humidity	10% RH~ 90% RH
Dimensions (WxHxD)	176mmx169mmx136mm
Weight	<1.1KG
Body color	grey

ANNEX 2 SIZE AND DIMENSION

Front

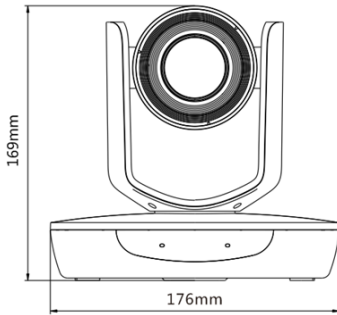

Rear

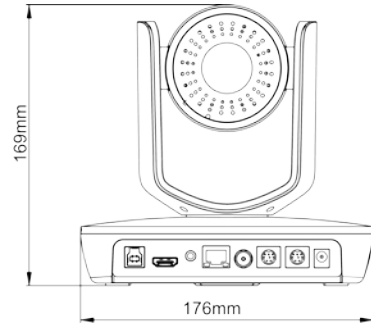

Top

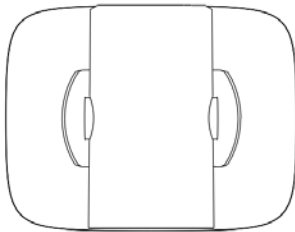

Side

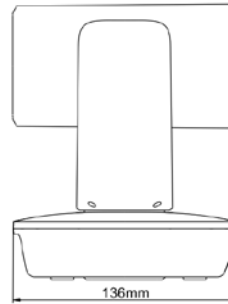

Bottom

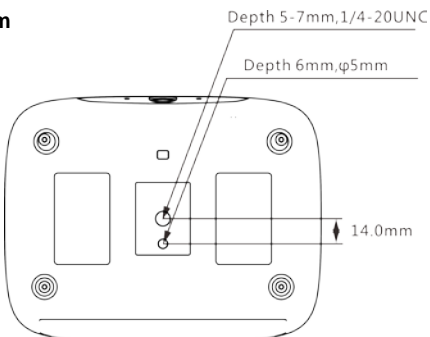

TROUBLESHOOTING

Problem	Possible Cause	Solution
No action or image after powered on	Power supply failure	Check power supply
	Power adapter damaged	Replace power adapter
	Power cable connection got loosen	Check & reconnect
No self-testing after powered on, or with motor noise	Power cable is too long	Use a shorter cable
	Power adapter damaged	Replace power adapter
	Mechanical failure	Repair
Not controllable from remote controller	Low battery of remote controller	Change battery for remote controller
	Exceed remote control distance	Control within distance of 8M
After power on, self-test successfully, but not controllable	Wrong address / protocol / baud rate	Check & set again
	Wrong connection or open circuit of RS-485 or RS-232 cable	Check & reconnect
Video loss when pans / tilts / zooms	Power cable is too long	Use a shorter cable
	Power adapter damaged	Replace power adapter
	Video cable not properly connected	Replace with a good video cable
Video captured after connected to digital video interface of a capture device is not good as the video captured after connected directly analog video interface of the capture device	Different video capture devices have different video capturing performance, image quality maybe worse after it has been converted from analog to digital	Consult video capture device supplier for more information

The user manual is only for a reference, if there are any changes or differences, please ask for the latest version from your supplier

Y06020900081