

# 4K PTZ Camera

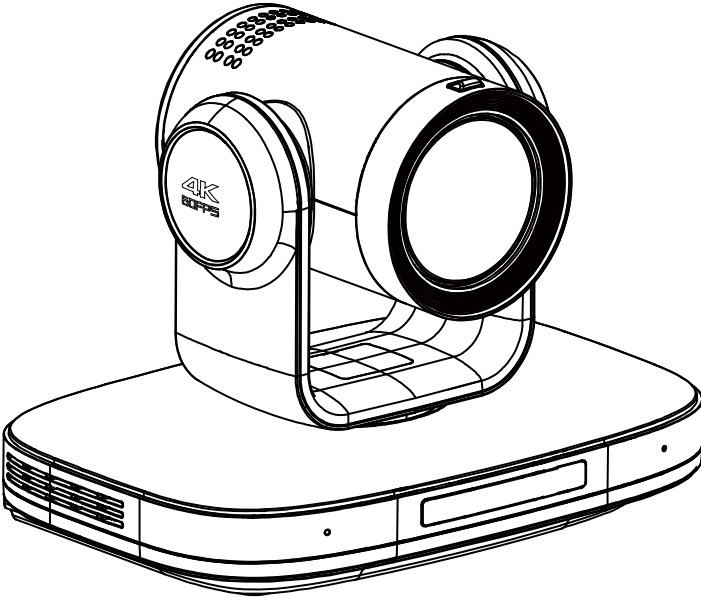

## User Manual

English (V1.0)

## Copyright

All contents of this manual, whose copyright belongs to our corporation, cannot be cloned, copied or translated without the permission of our corporation.

## Notice

Product specifications and information which were referred to in this document are for reference only. We may change, delete, or update any content at any time and without prior notice.

## FCC NOTICE (Class A)



This product complies with Part 15 of the FCC Rules. The operation is subject to the following two conditions: (1) this device may not cause harmful interference, and (2) this device must accept any interference received, including interference that may cause undesired operation.



Note

This product has been tested and found to comply with the limits for a Class A digital device, pursuant to Part 15 of the FCC Rules. These limits are designed to provide reasonable protection against harmful interference in a residential installation. This equipment generates uses and can radiate radio frequency energy and, if not installed and used in accordance with the instructions, may cause harmful interference to radio communications. However, there is no guarantee that interference will not occur in a particular installation. If this equipment does cause harmful interference to radio or television reception, which can be determined by turning the equipment off and on, the user is encouraged to try to correct the interference by one or more of the following measures:

- Reorient or relocate the receiving antenna.
- Increase the separation between the equipment and receiver.
- Connect the equipment into an outlet on a circuit different from that to which the receiver is connected.
- Consult the dealer or an experienced radio/television technician for help.

## Class A ITE

Class A ITE is a category of all other ITE which satisfies the class A ITE limits but not the class B ITE limits. Such equipment should not be restricted in its sale but the following warning shall be included in the instructions for use:



Operating this equipment in a residential environment may cause radio interference.

## European Community Compliance Statement (Class A)



This product is herewith confirmed to comply with the requirements set out in the Council Directives on the Approximation of the laws of the Member States relating to Electromagnetic Compatibility Directive 2014/30/EU.

# Catalogue

- 1** Note ..... 1
- 2** Packing List ..... 1
- 3** Quick Start..... 1
- 4** About Product..... 2
  - 4.1 Feature.....2
  - 4.2 Specification.....2
  - 4.3 Interface and Switch .....4
  - 4.4 Dimension.....4
  - 4.5 Installation .....5
  - 4.6 Remote Control .....6
- 5** GUI Settings..... 7
  - 5.1 MENU .....7
  - 5.2 EXPOSURE .....7
  - 5.3 COLOR .....7
  - 5.4 IMAGE .....8
  - 5.5 P/T/Z .....8
  - 5.6 NOISE REDUCTION .....8
  - 5.7 SETUP .....8
  - 5.8 COMMUNICATION SETUP .....9
  - 5.9 RESTORE DEFAULT .....9
- 6** WEB Settings ..... 9
  - 6.1 Access Camera .....9
  - 6.2 Control Camera .....9
  - 6.3 Video Settings.....10
  - 6.4 Image Settings.....11
  - 6.5 Audio Settings .....12
  - 6.6 System Settings.....12
  - 6.7 Network Settings.....12
  - 6.8 Device Information .....13
  - 6.9 Download Upgrade Program .....13
- 7** Troubleshooting ..... 14

### 1 Note

- During the installation and use of the equipment, all electrical safety regulations of the country and region of use must be strictly observed.
- Please use the power adapter that comes standard with this product.
- Please do not connect multiple devices to the same power adapter (exceeding the capacity of the adapter may generate excessive heat or cause a fire).
- Do not rotate head of the camera by hand, otherwise it may cause mechanical failure.
- When installing this product on a wall or ceiling, secure the device securely. When installing, make sure that there are no obstacles within the rotation range of the gimbal; do not turn on the power until all installations are completed.
- To avoid heat build-up, keep ventilation around the device smooth.

- If the device emits smoke, smells, or makes noises, please turn off the power immediately and unplug the power cord, and contact the dealer in time.
- This device is not waterproof, please keep the device dry.
- This product has no user serviceable parts, damage caused by disassembly by the user is not covered by the warranty.



**Notice**  
Specific frequencies of electromagnetic field may affect the image of the camera!

### 2 Packing List

Name	Quantity
Camera	1
Power Adapter	1
Power Cable	1
RS232 Cable	1
USB Cable	1
Remote Control	1
User Manual	1

### 3 Quick Start

1) Please check connections are correct before starting.

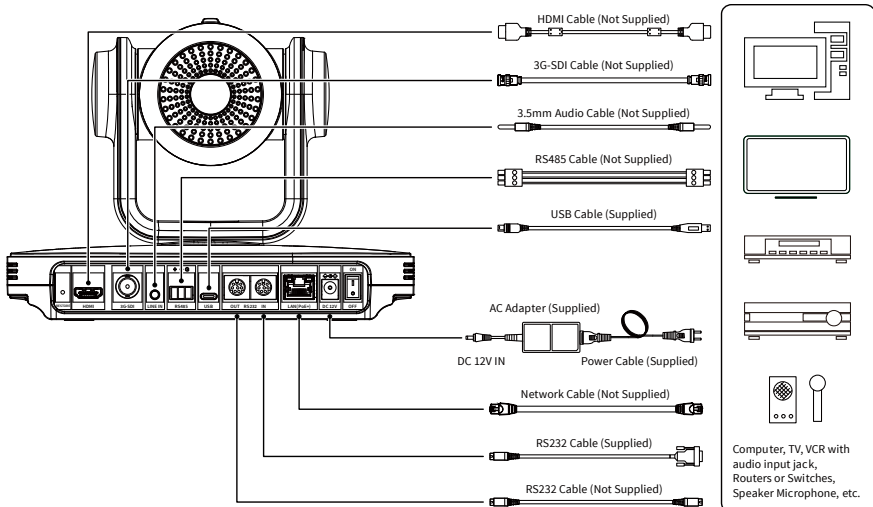

- 2) Connect the power adapter to the power connector on the rear panel of the camera. The power indicator on the front panel of the camera is on.
- 3) After the camera is powered on, it starts to initialize, right up to the limit position, and then both horizontal and vertical go to the middle position, the motor stops running, and the initialization is completed.  
(Note: If preset 0 is saved, PTZ will be move to preset 0)

## 4 About Product

### 4.1 Feature

#### ● AI Tracking

With the help of the AI computing power of the chip, the camera is equipped with advanced AI algorithms to realize monocular humanoid tracking, which can realize automatic tracking of scenes such as education, conferences and live broadcasts.

#### ● NDI|HX2 (Optional)

NDI|HX2 has the characteristics of low delay and plug and play, which is convenient for project implementation and deployment. It has good ecology and supports the simultaneous transmission of audio, video and control commands. It is a new generation of network video transmission mode.

#### ● 4K UHD

Use 1/2.8-inch high-quality UHD CMOS sensor with a maximum of 8.40 million pixels can realize 4K (3840x2160) ultra-high-resolution high-quality images. And downward compatible with 1080p, 720p and other resolutions.

#### ● 12x Optical Zoom

It adopts 4K ultra long focal lens with high quality and 8 million ultra-high resolution, 12x optical zoom, and the maximum field angle is 80.8°.

#### ● HDMI 2.0

Support HDMI 2.0 interface, which can directly output 4KP60 uncompressed digital video.

#### ● Low Light

The application of 3D noise reduction algorithm greatly reduces image noise. Even under the condition of ultra-low illumination, it still keep the picture clean and clear, and the SNR of image is as high as 55dB.

#### ● Multiple Interfaces

Support HDMI and 3G-SDI interface, effective transmission distance of 3G-SDI is up to 150 meters (1080P30). HDMI or 3G-SDI, USB, LAN can output three HD digital signals at the same time.

#### ● Remote Control

Through the RS232 and RS485 serial ports, the camera can be controlled remotely.

#### ● Gravity Sensor

It supports automatic image flipping function, which is convenient for engineering installation and use.

### 4.2 Specification

Camera	
Signal System	<b>HDMI:</b> 4KP25, 4KP30, 4KP50, 4KP60, 4KP59.94, 4KP29.97, 1080P25, 1080P30, 1080P50, 1080P60, 1080P59.94, 1080P29.97, 1080I50, 1080I60, 1080I59.94, 720P50, 720P59.94, 720P60 <b>3G-SDI:</b> 1080P25, 1080P30, 1080P50, 1080P60, 1080P59.94, 1080P29.97, 1080I50, 1080I60, 1080I59.94, 720P50, 720P59.94, 720P60
Sensor	1/2.8 inch, CMOS, Effective pixels: 8.40M
Scanning Mode	Progressive
Lens	12x, f = 3.4mm ~ 41.6mm, F1.8 ~ F3.7
Digital Zoom	16x
Minimum Illumination	0.5 Lux @ (F1.8, AGC ON)
Shutter	1/30s ~ 1/10000s

White Balance	Auto, Indoor, Outdoor, One Push, Manual, VAR
Backlight Compensation	Support
Digital Noise Reduction	3D Digital Noise Reduction
Signal Noise Ratio	≥55dB
Horizontal Angle of View	80.8° ~ 7.5°
Vertical Angle of View	49.9° ~ 4.3°
Horizontal Rotation Range	±170°
Vertical Rotation Range	-30° ~ +90°
Pan Speed Range	1.8°/s ~ 80°/s
Tilt Speed Range	1.5°/s ~ 49°/s
H & V Flip	Support
Image Freeze	Support
PoE+	Support
Number of Preset	255
Preset Accuracy	0.1°
<b>USB Features</b>	
Operate System	Windows 7/8/10, Mac OS X, Linux, Android
Color System/Compression	<ul style="list-style-type: none"> <li>● USB 3.0 (Optional): YUY2/H.264/MJPEG</li> <li>● USB 2.0: H.264/MJPEG</li> </ul>
Video Format	<ul style="list-style-type: none"> <li>● YUY2: (USB 3.0 support) max to 1080P@30fps</li> <li>● USB 3.0/2.0 support: H.264 AVC: max to 2160P@30fps</li> <li>● MJPEG: max to 2160P@30fps</li> </ul>
USB Audio	Support
USB Video Protocol	UVC 1.1 ~ 1.5
UVC PTZ	Support

<b>Network Features</b>	
Video Compression	H.264/MJPEG
Video Stream	First Stream, Second Stream
First Stream Resolution	3840x2160, 1920x1080, 1280x720, 1024x576, 720x480, 720x408, 640x480, 640x360
Second Stream Resolution	720x480, 720x408, 640x480, 640x360, 480x320, 320x240
Bit Rate Control	CBR, VBR
Frame Rate	50Hz: 1fps ~ 50fps 60Hz: 1fps ~ 60fps
Audio Compression	AAC
Audio Bit Rate	96Kbps, 128Kbps
Protocols	NDI® HX2, TCP/IP, HTTP, RTSP, RTMP/RTMPS, ONVIF, DHCP, SRT, Multicast
<b>Input/Output Interface</b>	
HDMI Interface	1 x HDMI: Version 2.0
3G-SDI Interface	1 x 3G-SDI: BNC type, 800mVp-p, 75Ω. Along to SMPTE 424M standard
LINE IN Interface	1 x LINE IN: 3.5mm Audio Interface
Communication Interface	1 x RS485: 3pin phoenix port, Max Distance: 1200m, Protocol: VISCA/Pelco-D/Pelco-P
	1 x RS232 IN: 8pin Min DIN, Max Distance: 30m, Protocol: VISCA/Pelco-D/Pelco-P
	1 x RS232 OUT: 8pin Min DIN, Max Distance: 30m, Protocol: VISCA network use
USB Interface	1 x USB: Type-C
LAN(PoE+) Interface	1 x LAN: 10M/100M/1000M Adaptive Ethernet Port, support PoE+
Power Jack	JEITA type (DC IN 12V)
<b>Physical Parameter</b>	
Tally Indicator	1

Power Indicator	1
Status Indicator	1
Restore Key	1
Power Switch	1
Input Voltage	DC 12V/PoE+(802.3at)
Input Current	Max. 2A
Operating Temperature	0°C ~ 40°C
Storage Temperature	-40°C ~ 60°C
Power Consumption	Max. 18W
Dimension	223mm x 163mm x 166mm
Net Weight	About 1.8Kg



Product specifications and parameters are subject to change without notice.

### 4.3 Interface and Switch

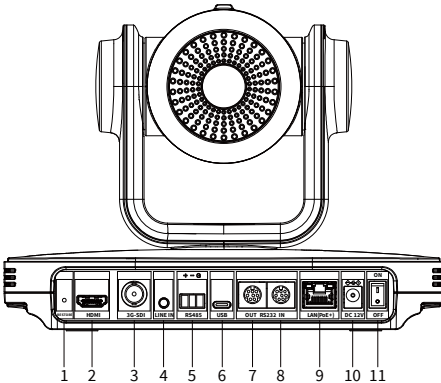

Item	Name
1	RESTORE Key
2	HDMI Interface
3	3G-SDI Interface
4	LINE IN Interface
5	RS485 Interface
6	USB Interface
7	RS232 OUT Interface
8	RS232 IN Interface
9	LAN(PoE+) Interface
10	DC 12V Interface
11	Power Switch

### 4.4 Dimension

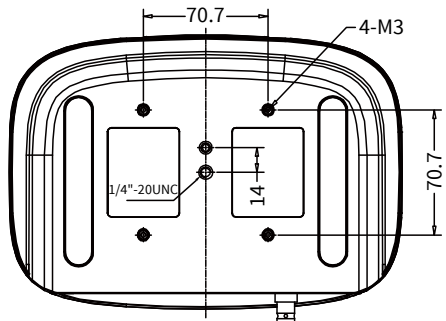
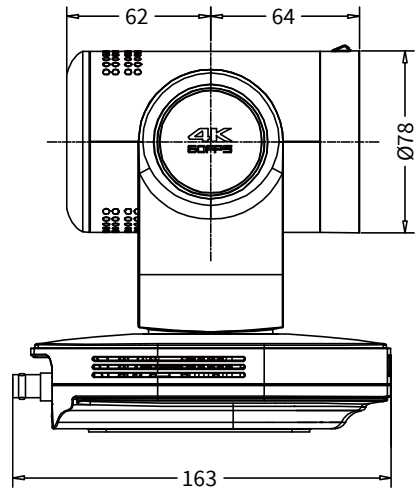
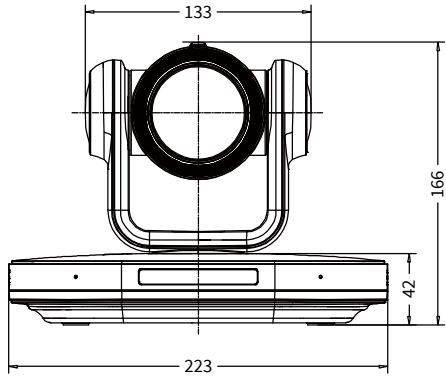

### 4.5 Installation

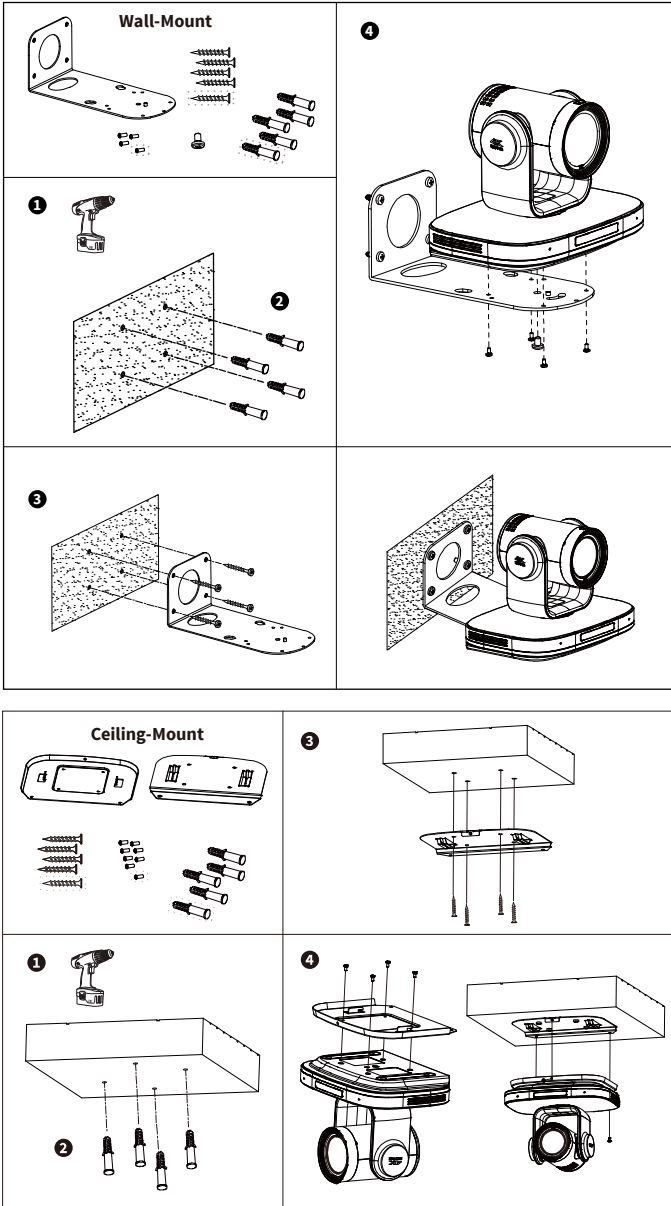

The installation diagram is for reference only. The brackets and screws are not standard. For packing accessories, please refer to the actual product.



### 4.6 Remote Control

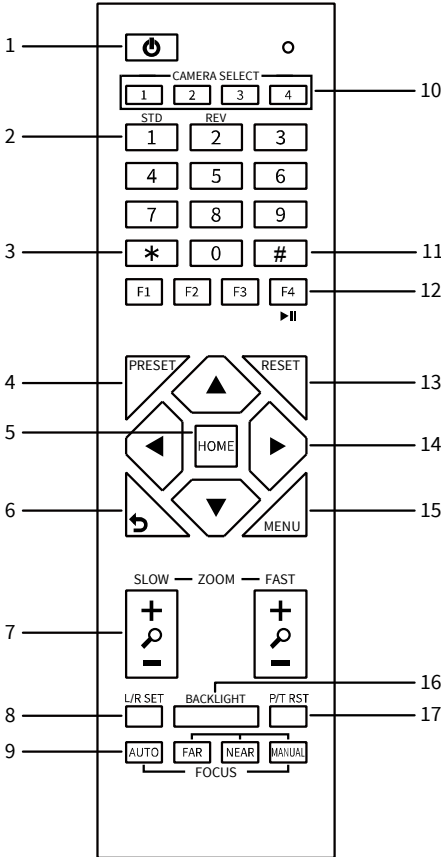

#### Key Description

##### 1. Standby Key

Press to enter standby mode

##### 2. Number Key

Press to set preset or call preset

##### 3. \*Key

Use with other keys

##### 4. PRESET Key

Set preset: [PRESET] + Number key (0-9)

##### 5. HOME Key

Confirm selection or press to turn PTZ back to the middle position

##### 6. Return Key

Press to return to the previous menu

##### 7. ZOOM Key

- SLOW: Zoom In [+] or Zoom Out [-] slowly
- FAST: Zoom In [+] or Zoom Out [-] fast

##### 8. L/R SET Key

- Standard: Simultaneously press L/R SET + 1
- Reverse: Simultaneously press L/R SET + 2

##### 9. FOCUS Key

Auto/Manual/Far/Near focus

##### 10. CAMERA SELECT Key

Press to select and control the camera

##### 11. # Key

Use with other keys

##### 12. IR Remote Control Key

- [\*]+[#]+[F1]: Address 1
- [\*]+[#]+[F2]: Address 2
- [\*]+[#]+[F3]: Address 3
- [\*]+[#]+[F4]: Address 4

##### 13. RESET Key

Clear preset position: [RESET] + Number key (0-9)

##### 14. PTZ Control Key

PTZ moved according to the arrow indicates

##### 15. MENU Key

Press to enter or exit OSD Menu

##### 16. BACKLIGHT Key

Backlight ON/OFF: Press repeatedly to enable or disable the backlight compensation.

NOTE:

- Effective only in auto exposure mode.
- If there is a light behind the subject, the subject will become dark, press the backlight key to enable the backlight compensation. Press again to disable this function.

##### 17. P/T RST (PTZ Reset) Key

PTZ starts to self-test after pressed it

##### Shortcut Set

- [\*]+[#]+[1]: OSD menu default English
- [\*]+[#]+[3]: OSD menu default Chinese
- [\*]+[#]+[4]: Display current IP address
- [\*]+[#]+[6]: Quickly recover the default
- [\*]+[#]+[8]: View the camera version
- [\*]+[#]+[9]: Quickly set up inversion
- [\*]+[#]+[MANUAL]: Restore default IP address

## 5 GUI Settings

### 5.1 MENU

Press [MENU] key to display the main menu on the normal screen, using arrow key to move the cursor to the item to be set. Press the [HOME] key to enter the corresponding sub-menu.

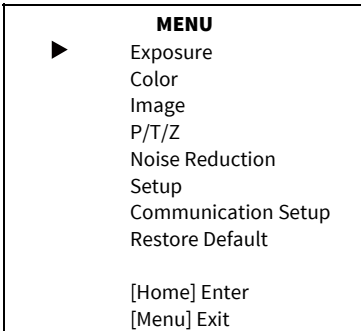

### 5.2 EXPOSURE

Move the main menu cursor to [Exposure], and press [HOME] key enter the exposure page, as shown in the following figure.

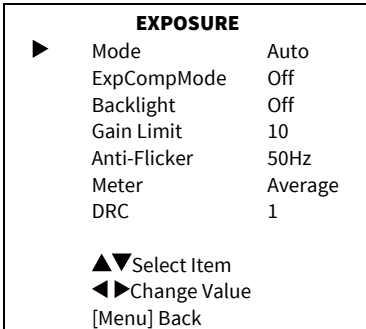

**Mode:** Auto, Manual, SAE, AAE, Bright.

**ExpCompMode:** On, Off (Effective only in Auto mode).

**ExpComp:** -7 ~ 7 (Effective only in ExpCompMode item to On).

**Backlight:** On, Off (Effective only in Auto mode).

**Bright:** 0 ~ 17 (Effective only in Bright mode).

**Gain Limit:** 0 ~ 15 (Effective only in Auto, SAE, AAE, Bright mode).

**Anti-Flicker:** Off, 50Hz, 60Hz (Effective only in Auto, AAE, Bright mode).

**Meter:** Average, Center, Smart, Top.

**Iris:** F1.8, F2.0, F2.4, F2.8, F3.4, F4.0, F4.8, F5.6, F6.8, F8.0, F9.6, F11.0, Close (Effective only in Manual, AAE mode).

**Shutter:** 1/30, 1/60, 1/90, 1/100, 1/125, 1/180, 1/250, 1/350, 1/500, 1/725, 1/1000, 1/1500, 1/2000, 1/3000, 1/4000, 1/6000, 1/10000 (Effective only in Manual, SAE mode).

**Gain:** 0 ~ 7 (Effective only in Manual mode).

**DRC:** 0 ~ 8.

### 5.3 COLOR

Move the main menu cursor to [Color], and press [HOME] key enter the color page, as shown in the following figure.

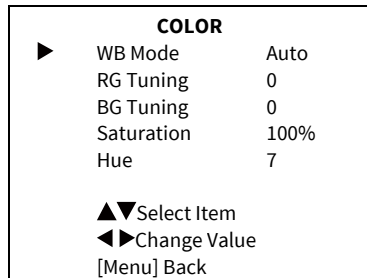

**WB Mode:** Auto, Indoor, Outdoor, One Push, Manual, VAR.

**RG:** 0 ~ 255 (Effective only in Manual mode).

**BG:** 0 ~ 255 (Effective only in Manual mode).

**RG Tuning:** -10 ~ +10 (Effective only in Auto, One Push, VAR Mode).

**BG Tuning:** -10 ~ +10 (Effective only in Auto, One Push, VAR Mode).

**Saturation:** 60% ~ 200%.

**Hue:** 0 ~ 14.

**Color Temp:** 2500K ~ 8000K (Effective only in VAR mode).

## 5.4 IMAGE

Move the main menu cursor to [Image], and press [HOME] key enter the image page, as shown in the following figure.

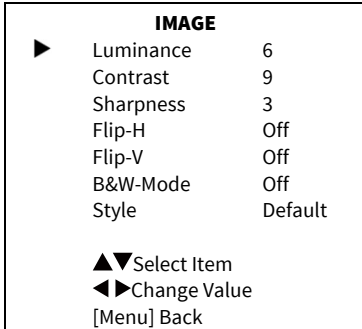

**Luminance:** 0 ~ 14.

**Contrast:** 0 ~ 14.

**Sharpness:** 0 ~ 15, auto.

**Flip-H:** On, Off.

**Flip-V:** On, Off.

**B&W-Mode:** On, Off.

**Style:** Default, Norm, Bright, PC.

## 5.5 P/T/Z

Move the main menu cursor to [P/T/Z], and press [HOME] key enter the P/T/Z page, as shown in the following figure.

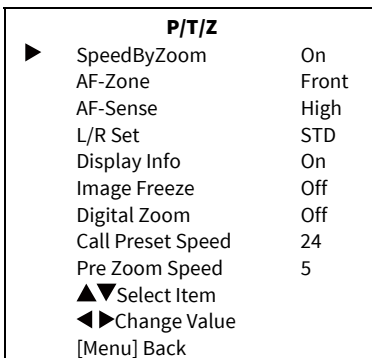

**SpeedByZoom:** On, Off.

**AF-Zone:** Front, Top, Center, Bottom.

**AF-Sense:** Low, Normal, High.

**L/R Set:** STD, REV.

**Display Info:** On, Off.

**Image Freeze:** On, Off.

**Digital Zoom:** Off, 2x, 4x, 8x, 16x.

**Call Preset Speed:** 1 ~ 24.

**Pre Zoom Speed:** 0 ~ 7.

## 5.6 NOISE REDUCTION

Move the main menu cursor to [Noise Reduction], and press [HOME] key enter the noise reduction page, as shown in the following figure.

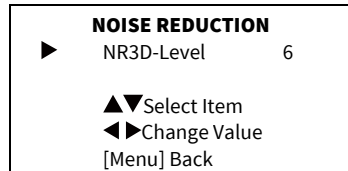

**NR3D Level:** Off, 1 ~ 9.

## 5.7 SETUP

Move the main menu cursor to [Setup], and press [HOME] key enter the setup page, as shown in the following figure.

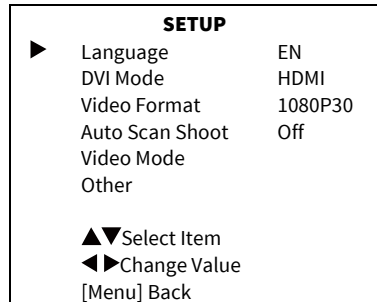

**Language:** EN, Chinese, Russian.

**DVI Mode:** HDMI, DVI.

**Video Format:** 4KP25, 4KP29.97, 4KP30, 4KP50, 4KP59.94, 4KP60, 1080P30, 1080P25, 1080P50, 1080P60, 1080P59.94, 1080P29.97, 1080I50, 1080I60, 1080I59.94, 720P60, 720P59.94, 720P50.

**Auto Scan Shoot:** On, Off.

**Video Mode:** SDI-3G Mode, Video Output.

**SDI-3G Mode:** LEVEL-A, LEVEL-B.

**Video Output:** HDMI, SDI.

**Other:** Auto Inversion, Tally Mode, USB2.0 Audio.

**Auto Inversion:** On, Off.

**Tally Mode:** On, Off.

**USB2.0 Audio:** On, Off (Only for USB2.0).

### 5.8 COMMUNICATION SETUP

Move the main menu cursor to [Communication Setup], and press [HOME] key enter the communication setup page, as shown in the following figure.

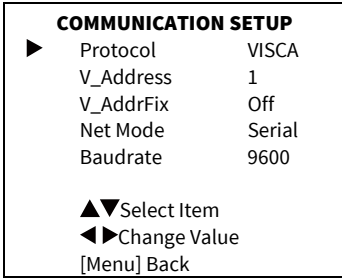

**Protocol:** Auto, VISCA, PELCO-D, PELCO-P.

**V\_Address:** 1 ~ 7 (Effective only in Auto, VISCA protocol).

**V\_AddrFix:** On, Off (When set to On, useless in 88 30 01 FF Command).

**P\_D\_Address:** 0 ~ 254 (Effective only in Auto, PELCO-D protocol).

**P\_P\_Address:** 0 ~ 31 (Effective only in Auto, PELCO-P protocol).

**Net Mode:** Serial, Paral.

**Baudrate:** 2400, 4800, 9600, 38400.

### 5.9 RESTORE DEFAULT

Move the main menu cursor to [Restore Default], press [HOME] key enter restore default page, as shown in the following figure.

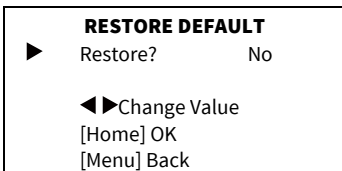

**Restore:** Yes, No.



GUI menu and parameters are subject to change without notice.

## 6 WEB Settings

### 6.1 Access Camera

Access <http://192.168.100.88> to pop up the login window, then input username (default: admin) and password (default: admin). After login, it will show as below:



### 6.2 Control Camera

All pages include two menu bars:

Real time monitoring: displaying video image

Parameter setup: with function buttons.

#### A. Video Viewing Window

Video viewing window must be same as video resolution, the bigger the resolution is, the bigger the playing area is. Double click viewing window, will show full-screen, double click again, will return to initialized size.

Status bar in viewing window shown as below:

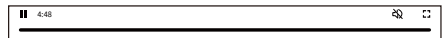

- 1) Video playback pause button: control real-time video pause, stop the last picture, click recoverable video again.
- 2) Audio control buttons: can adjust the volume or set silent mode.
- 3) Full screen switch button.

**B. PTZ Setup**

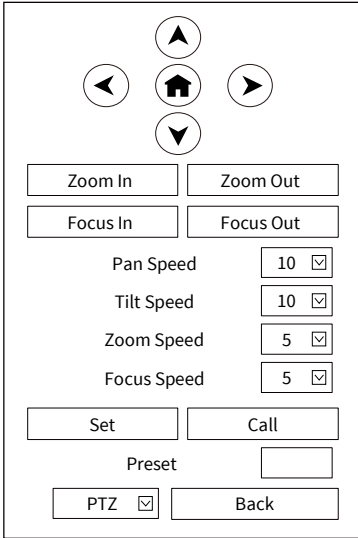

**1) Pan and Tilt Control**

Up, Down, Left and Right arrows and the home button allow you to manually drive the camera to the desired position.

**2) Zoom**

Zoom In and Zoom Out buttons allow for wide or narrow view of the space.

**3) Focus**

Focus In and Focus Out buttons allow for fine manual focus adjustment if the camera has any problems auto focusing on the difficult object.

**4) PTZ Speeds**

Pan speed can be set at any rate between 1 ~ 24, Tilt speed can be set at any rate between 1 ~ 20. Zoom and Focus speeds can be set at any rate between 1 ~ 7.

**5) PTZ Presets**

After manually setting up a shot that you would like to return to later, you can save presets for quick recall of these positions. Type a number between 0 and 254 into the Preset box.

Click the “Set” button to save the current location with that preset number. Click the “Call” button to cause the camera to return to that position. This enables smooth, quick and convenient control without the need to manually drive the camera.

You can set up preset that user want as below.

Method: Type preset number into the Preset box.



Preset: Optional items: 0 ~ 254.

**6) PTZ/OSD Dropdown**

From the dropdown menu, clicking the OSD option will open the on-screen display menu of the camera giving you control from within the IP interface.

**C. Language Selection**

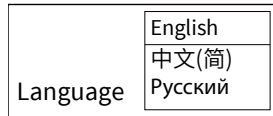

Click either “Chinese”, “English” or “Russian” to change the language of the webpage.

**6.3 Video Settings**

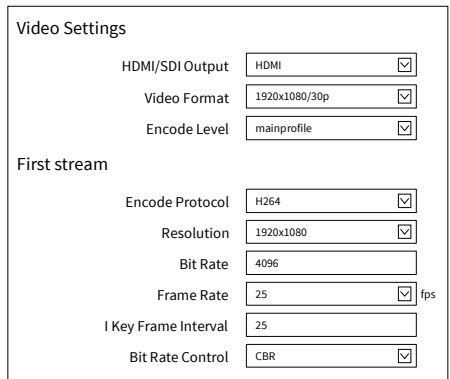

Second stream

Encode Protocol

Resolution

Bit Rate

Frame Rate  fps

I Key Frame Interval

Bit Rate Control

**1) HDMI/SDI Output**

Support HDMI and SDI Output.

**2) Video Format**

HDMI output support 3840x2160/60p, 3840x2160/59.94p, 3840x2160/50p, 3840x2160/30p, 3840x2160/29.97p, 3840x2160/25p. Both HDMI and SDI output support 1920x1080/60p, 1920x1080/59.94p, 1920x1080/50p, 1920x1080/60i, 1920x1080/59.94i, 1920x1080/50i, 1920x1080/30p, 1920x1080/29.97p, 1920x1080/25p, 1280x720/60p, 1280x720/59.94p, 1280x720/50p.

**3) Encode Level**

Support mainprofile and highprofile two levels.

**4) Encode Protocol**

Support H.264, and MJPEG protocols.

**5) Resolution**

First stream support 3840x2160, 1920x1080, 1280x720, 1024x576, 720x480, 720x408, 640x480, 640x360. Second stream support 720x480, 720x408, 640x480, 640x360, 480x320, 320x240; The bigger resolution is, the clearer the image will be, more network bandwidth will be taken.

**6) Bit Rate**

The user can specify the bit rate. Generally speaking, the larger of the bit rate, the clearer of the image. However, the configuration of the bit rate needs to be combined with the network bandwidth. When the network bandwidth is narrow and the bit rate is configured larger, the video stream cannot be transmitted normally, and the visual effect is worse.

**7) Frame Rate**

User can specify the size of the frame rate, generally, the frame rate greater, the image more smooth; Frame rate is smaller, the more sense of beating.

**8) I Key Frame Interval**

Set interval between 2 I frame, the bigger interval is the response will be lower from view window.

**9) Bit Rate Control**

Code stream control way:

CBR (Constant Bit Rate): Video coder will be coding according to preset speed.

VBR (Variable Bit Rate): Video coder will adjust the speed based on preset speed to gain the best image quality.

**6.4 Image Settings**



Brightness  6

Saturation  4

Contrast  9

Sharpness  3

Hue  7

Flip  On  Off

Mirror  On  Off

**1) Brightness**

Brightness of image: 0~14 (Default value is 6).

**2) Saturation**

Saturation of image: 0~14 (Default value is 4).

**3) Contrast**

Contrast of image: 0~14 (Default value is 9).

**4) Sharpness**

Sharpness of image: 0~16 (Default value is 3).

**5) Hue**

Hue of image: 0~14 (Default value is 7).

**6) Flip**

Turn On/Off the Flip function.

**7) Mirror**

Turn On/Off the Mirror function.

**6.5 Audio Settings**

Audio Settings

Audio Switch  On

Audio Type  AAC

Sample Rate  48K

Bit Rate  96K

Input Type  LINE IN

Input Vol  20  dB

ADTS Options  Off

**1) Audio Switch**

Enable or disable audio switch.

**2) Audio Type**

Optional items: AAC.

**3) Sample Rate**

Optional items: 44.1K, 48K.

**4) Bit Rate**

Optional items: 96K, 128K.

**5) Input Type**

Optional items: LINE IN, MIC.

**6) Input Vol**

The volume of the channel.

**7) ADTS Options**

Optional items: On, Off.

**6.6 System Settings**

Initialize

Reboot

User

UserName

Passwd

Guest

Passwd

**1) Reboot**

Click the “Reboot” button, system restart.

**2) Username and Password**

The user can modify the password (letters and Numbers only).

**6.7 Network Settings**

Lan Settings

IP Configuration Type  Fixed IP Address

IP Address

Subnet Mask

Gateway

DNS Address

MAC Address

Port Settings

HTTP Port

RTSP Port

TCP Port

UDP Port

Sony Visca

RTMP(S) Settings

First Stream  On  Off  Video  Audio

MRL

Second Stream  On  Off  Video  Audio

MRL

SRT Settings

SRT  On  Off

SRT Port

SRT Encryption  None

SRT Password

RTSP Settings

RTSP Auth  On  Off

ONVIF Settings

ONVIF  On  Off

ONVIF Auth  On  Off

Multicast Settings

Multicast  On  Off

Address

Port

NTP Settings

NTP time sync  On  Off

Time Zone

Server address

Time interval(min)

Main time show  On  Off

Position

Sub time show  On  Off

Position

**1) Lan Settings**

Default the IP address is 192.168.100.88, the MAC address cannot be modified.

**2) Port Settings**

**A. HTTP Port**

IP address identifies the network device, the device can run multiple web applications, each network program using network port to transmit data, so data transmission to be carried out between the port and port. Port setting is to set up web server program using which port to transmit. When port mapping, need to be consistent with the port number (default port: 80).

**B. RTSP Port**

The 4K PTZ camera support RTSP protocol, use the VLC tools broadcast, default port: 554.

**C. TCP Port**

Support TCP connection then control camera, default port: 5678.

**D. UDP Port**

Support UDP protocol, default port: 1259.

**E. Sony Visca**

Support Sony Visca, default value: 52381.

**3) RTMP(S) Settings**

Setting the MRL of RTMP, select enable or disable video and audio. You can select control code stream of “On”, “Off”, “Video”, “Audio” between in the two streams.

**4) SRT Settings**

Turn On/Off SRT, Setting the SRT Port, SRT Encry and SRT Password.

**5) RTSP Settings**

Turn On/Off RTSP Auth.

**6) ONVIF Settings**

Turn On/Off ONVIF and ONVIF Auth.

**7) Multicast Settings**

Turn On/Off multicast. Setting the multicast address (default value is 224.1.2.3) and port (default value is 6688, then 6688 is the multicast port of the first stream; 6690 is the multicast port of the second stream).

**8) NTP Settings**

Turn On/Off NTP time sync, main time show and sub time show. Setting NTP server address, time interval, main stream position and sub stream position.

**6.8 Device Information**

Information

Device ID

Device Type

Software Version

Webware Version

**6.9 Download Upgrade Program**

If you need the camera upgrade program, please contact the manufacturer.



WEB interface and parameters are subject to change without notice.



## 7 Troubleshooting

### Image

- The monitor shows no image
  - 1) Check that the camera power supply is connected, the voltage is normal, and the power indicator light is always on.
  - 2) Turn off the power switch to check whether the camera is self-testing.
  - 3) Check the cable of video platform and TV whether correct connection.
- The video image displayed by the camera lens is jittery
  - 1) Check whether the camera installed position be stabled.
  - 2) Check whether have vibrating machinery or object near the camera.
- There is no video image in Browser
 

IE browser does not support H5, you need to use VLC plug-in to view videos. Please access VLC website (<http://www.videolan.org/vlc>) download and install the 32-bit VLC media player, after it installed, access 4K PTZ camera will have normal image display. Other mainstream browsers already support H5 and do not need to install the VLC plug-in.

- Unable to access 4K PTZ camera through Browser
  - 1) Using PC to access the network to test whether the network access can work properly, first of all, the network fault caused by the PC virus can be eliminated, until the PC and 4K PTZ camera can communicate with each other Ping.
  - 2) Disconnect the network, connect 4K PTZ camera and PC separately, and reset the IP address of PC.
  - 3) Check IP address, subnet mask, and gateway settings for 4K PTZ camera.
  - 4) Check whether the MAC address is conflicts.
  - 5) Check whether the web port is modified. The default web port is 80.
- Forget the IP address or login password
 

Please remember (The default IP address: 192.168.100.88; default user name: admin; default password: admin).

### Control

- Remote control cannot control
  - 1) Check and replace the new battery for the remote controller.
  - 2) Check whether the camera working mode is correct.
  - 3) Check whether the address of remote control can match the camera.
- Serial port cannot control
  - 1) Check whether the camera protocol, address and baud rate such is the same.
  - 2) Check whether the control line is connected well.



079.79.1101351\_V1.0